

1000V Series

EXIT DEVICE

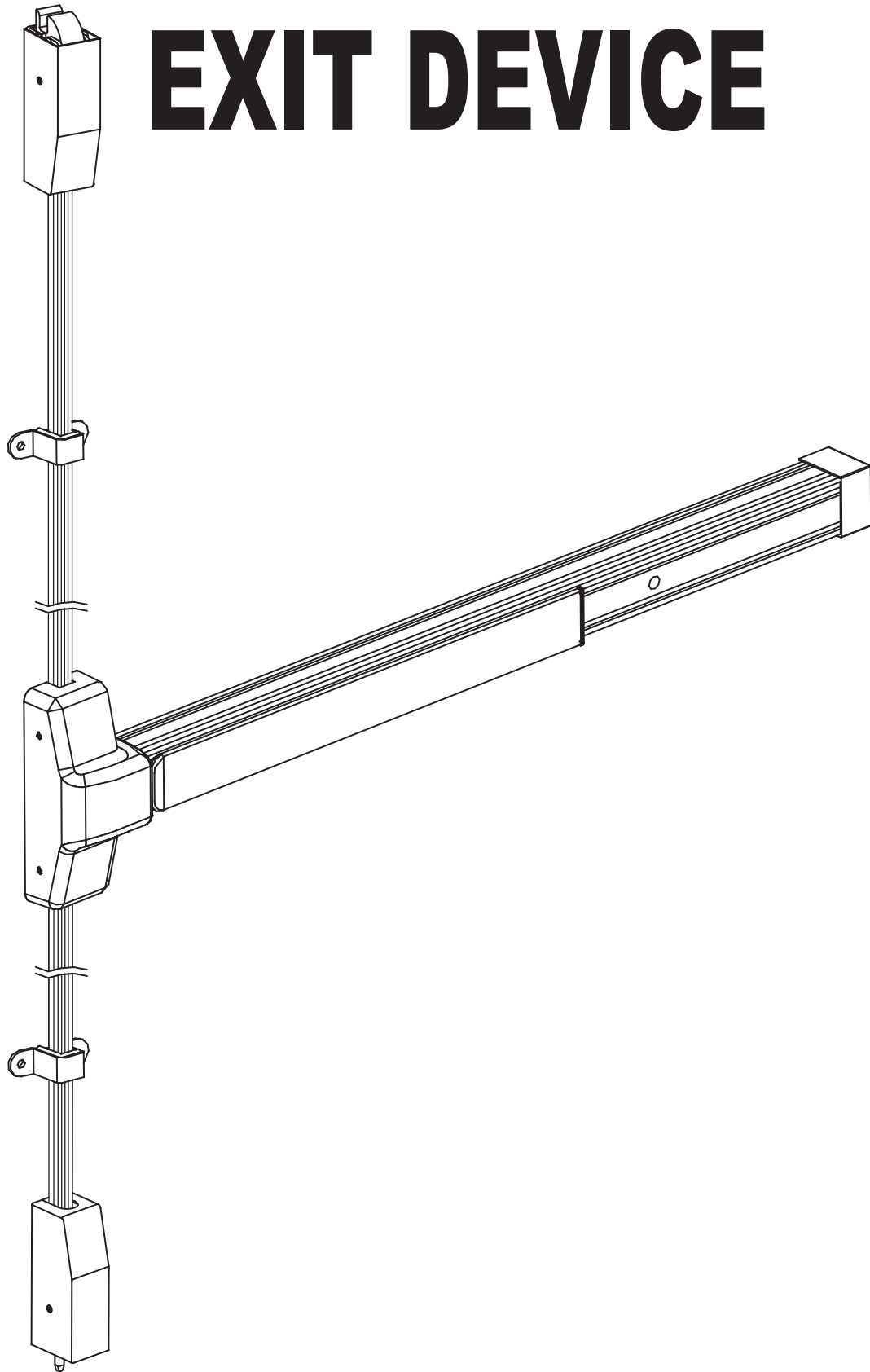

INSTALLATION INSTRUCTIONS

STEP 1 : DIRECTIONS FOR CHANGING HANDING OF DEVICE

Handing of device is preset at factory for RHR. To change handing of device, follow steps shown below and see DRAWING FOR STEP 1.

1. Loosen screw 'A' and remove screw 'B' and spring 'C'.
2. Reverse the positions of screw 'B' and spring 'C' and then tighten screw 'A'.
3. The device is now set for LHR.

STEP 2 : MARK CENTER LINE ON DOOR

Mark center line on inside of door .
Establish the horizontal center line of the device by drawing a line across the door 40" above floor line.

STEP 3 : MARK DOOR AND DRILL HOLES

1. Fold and apply template (A) to edge of door and mark door as indicated on template (A).
2. Drill holes A X 6 in accordance with the diameters as indicated on template (A)

END COVER

STEP 4 : INSTALL DEVICE BODY

1. Remove the head cover from the device body and end cover from the mounting bracket by removing the screws that hold them on.
2. Align tailpiece receiver of exit device and trim/cylinder tailpiece, so it slides onto trim/cylinder tailpiece. Also align screw holes on exit device head with mounting holes on the door.
3. Install and tighten the mounting screws for the head of the exit device and end cover mounting bracket.

STEP 5 : INSTALL TOP STRIKE

1. Align vertical center line of top strike and top rod as shown on template (B-1)
Mark door as indicated on template (B-1).
2. Install top strike with it's mounting screws and adjust as needed.

STEP 6 : INSTALL TOP LATCH ASSEMBLY

1. Align vertical center line of top latch assembly and top rod as shown on template(B-1)
Mark door as indicated on template(B-1).
2. Drill hole C, 2" from bottom edge of door frame.
3. Align top latch base with hole C and install screw but do not tighten all the way.

Install rod guides onto top and bottom rods at the midway point .

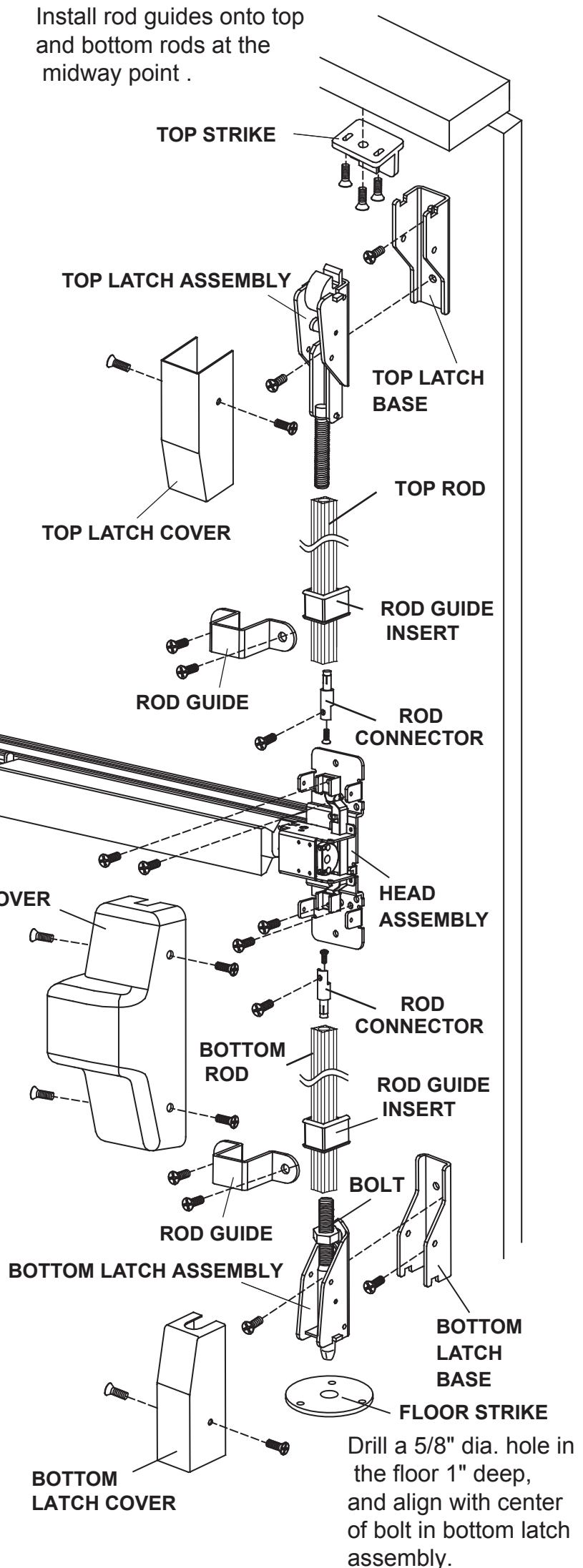

DRAWING FOR STEP 1

4. Install top latch assembly into top latch base. Adjust the location of the top latch assembly and top latch base per Template B-1 to get 3/32" space between top strike and inside of top latch bolt.
5. Remove top latch assembly and tighten screw C.
6. Drill hole D, Reinstall top latch assembly into top latch base and tighten screw D.

STEP 7 : INSTALL BOTTOM LATCH ASSEMBLY

1. Align vertical center line of bottom latch assembly and bottom rod as shown on template Mark door as indicated on template (B-2).
CAUTION : Be sure the distance from the bottom edge of door to the bottom latch base is 13/32".
2. Drill hole C, 1 1/4" from bottom edge of door.
3. Align bottom latch base with hole C, adjust its location to have 13/32" between the bottom of the door and the bottom edge of the bottom latch base. Then tighten screw C.
4. Drill hole D, install bottom latch assembly into bottom latch base and tighten screw D.

STEP 8 : INSTALL AND ADJUST TOP ROD (USE LONGER ROD)

1. Keep the end of the top rod with the threaded hole upward to connect it with the threaded bolt (thread onto bolt approx. 1") in the top latch assembly.
2. Put rod guide insert onto top rod.
3. Put rod connector into bottom unthreaded end of top rod and tighten screw to secure into rod.
4. Remove the screw on the head assembly, connect the bottom of rod connector with head assembly and reinstall screw but not tighten it all the way.
5. Push actuating bar down to check operation. Cut off extra rod length to make top rod work properly. Then tighten screw all the way.

NOTE : Top rod must be cut to correct length, leave 1" of adjustability for latch adjustment. Cut top rod at bottom end without threads. (DO NOT CUT END WITH THREADS)

STEP 9 : INSTALL AND ADJUST BOTTOM ROD (USE SHORTER ROD)

1. Keep the end of the bottom rod with the threaded hole downward to connect it with the threaded bolt (thread onto bolt approx. 1") in the bottom latch assembly.
2. Put rod guide insert onto bottom rod.
3. Put rod connector into top unthreaded end of top rod and tighten screw to secure into rod.
4. Remove the screw on the head assembly, connect the bottom of rod connector with head assembly and reinstall screw and tighten.

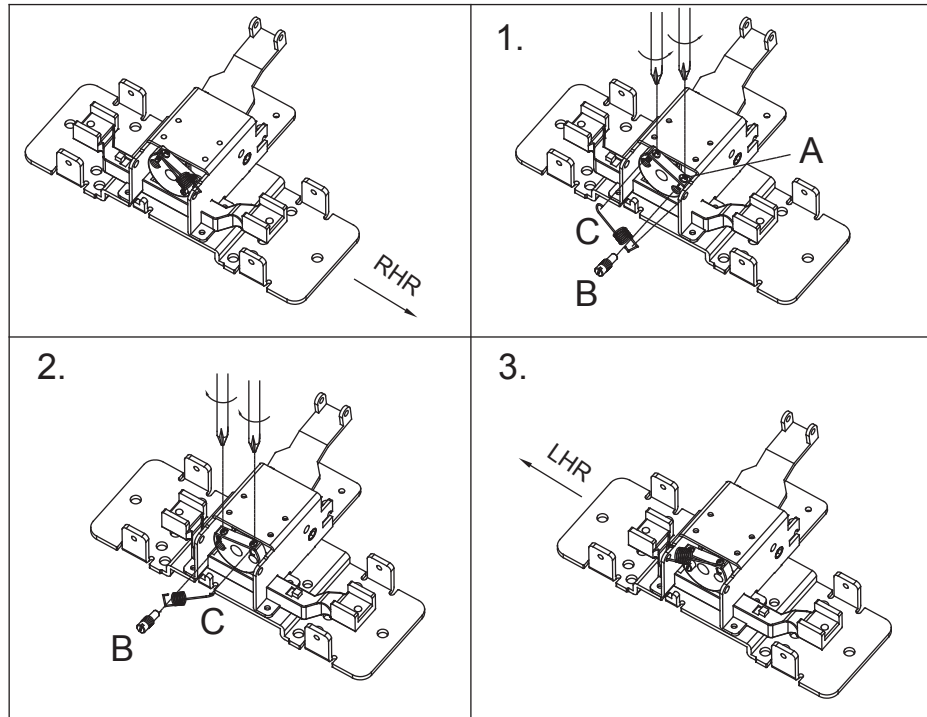

STEP 10 : INSTALL FLOOR STRIKE

1. Let the bolt in the lower bottom latch assembly touch the floor and mark on floor.
2. Drill a 5/8" dia, 1" deep hole.
3. Let the bolt in the lower bottom latch assembly insert into the center hole of floor strike and mark 3 anchor / screw holes on floor.
4. Drill 3 anchor / screw holes, 1/4" dia, 1 1/8" deep.
5. Hammer 3 anchors into 3 anchor / screw holes. Tighten up 3 screws.

STEP 11 : TEST ACTUATING BAR AND DOGGING OPERATION

1. The top latch assembly should engage the top strike and the bottom latch assembly should engage the floor strike when the door is closed. If the door can be pushed open without depressing the actuating bar, the top rod has been over adjusted. Readjust as needed for proper latching.
2. The top and bottom latch assembly should disengage from the strikes freely when the actuating bar is depressed. If they do not disengage, adjust the bolt in the bottom latch assembly as needed and retest for proper operation.

STEP 12: INSTALL TWO ROD GUIDES

1. Put rod guides onto top and bottom rods at the
2. midway point and mark and drill holes. Fit rod guide insert into rod guide and then install and tighten screws.

STEP 13: INSTALL 4 COVERS

Install head cover, end cover, top latch cover, bottom latch cover and tighten screws.

PARTS IDENTIFICATION

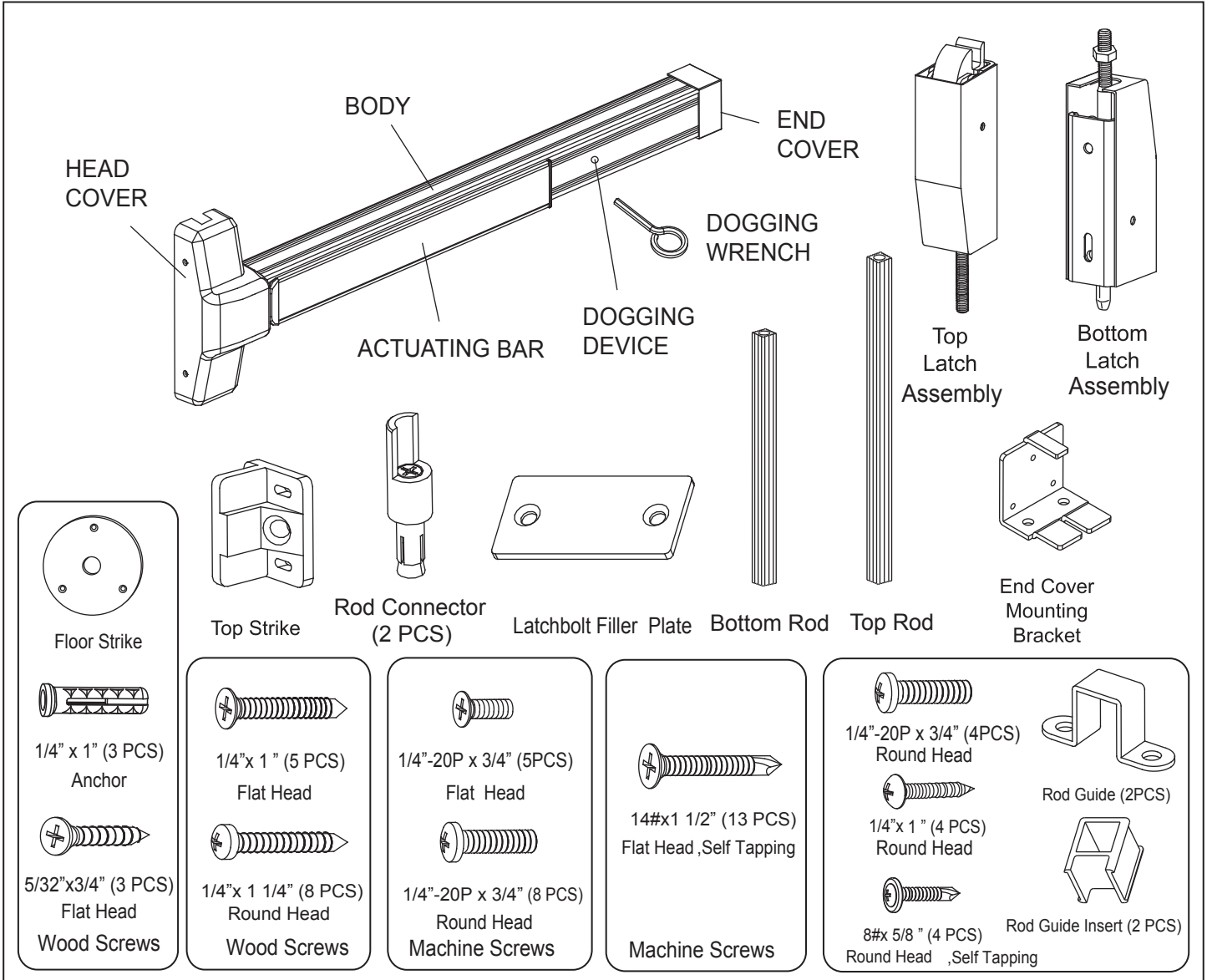

DOOR HANDING

Note: If door is LHR , please refer to step 1

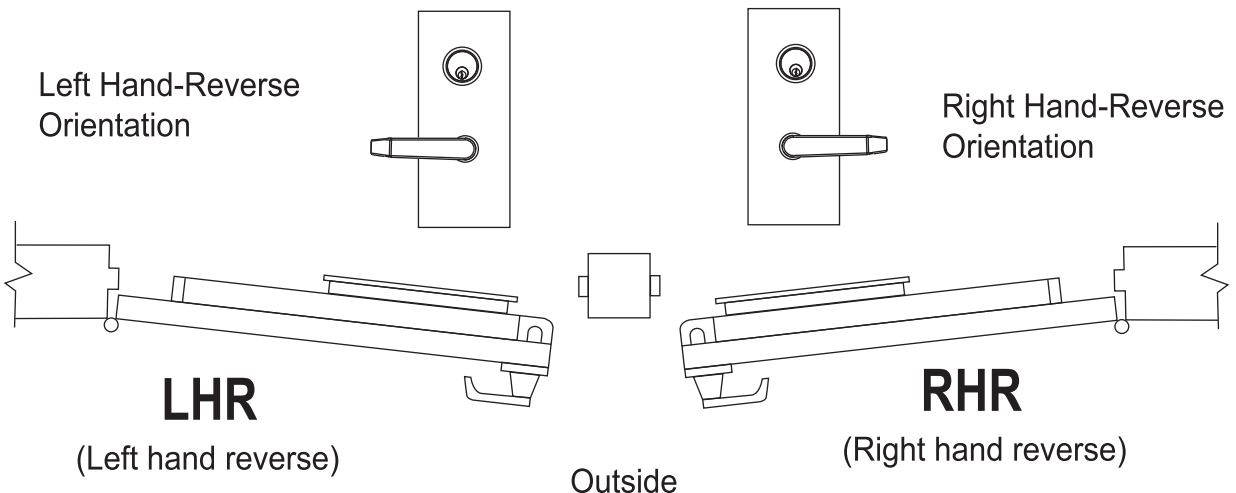

(A) For 1000V Series (UL Listed)-Drill & tap for (6) 1/4"-20P x 3/4" machine screws for exit device.

Drill (6) 3/16" pilot holes for self-tapping machine screws or wood screws for exit device.

TEMPLATE (A)

(B) For F1000V (Fire Rated)-Drill 9/32" holes inside and 3/8" holes outside for the (6) thru bolts.

FOR RIGHT HAND DOOR INSTALLATION

FOR LEFT HAND DOOR INSTALLATION

1/4"-20P x 3/4" x 6
Round Head Screws

1/4"-20P x 3/4" x 6
Round Head Screws

(When installing 1000R x 1000V on a pair of doors, a Double
Door Strike (DDS) is required. For complete template
information, please refer to the DDS template.)

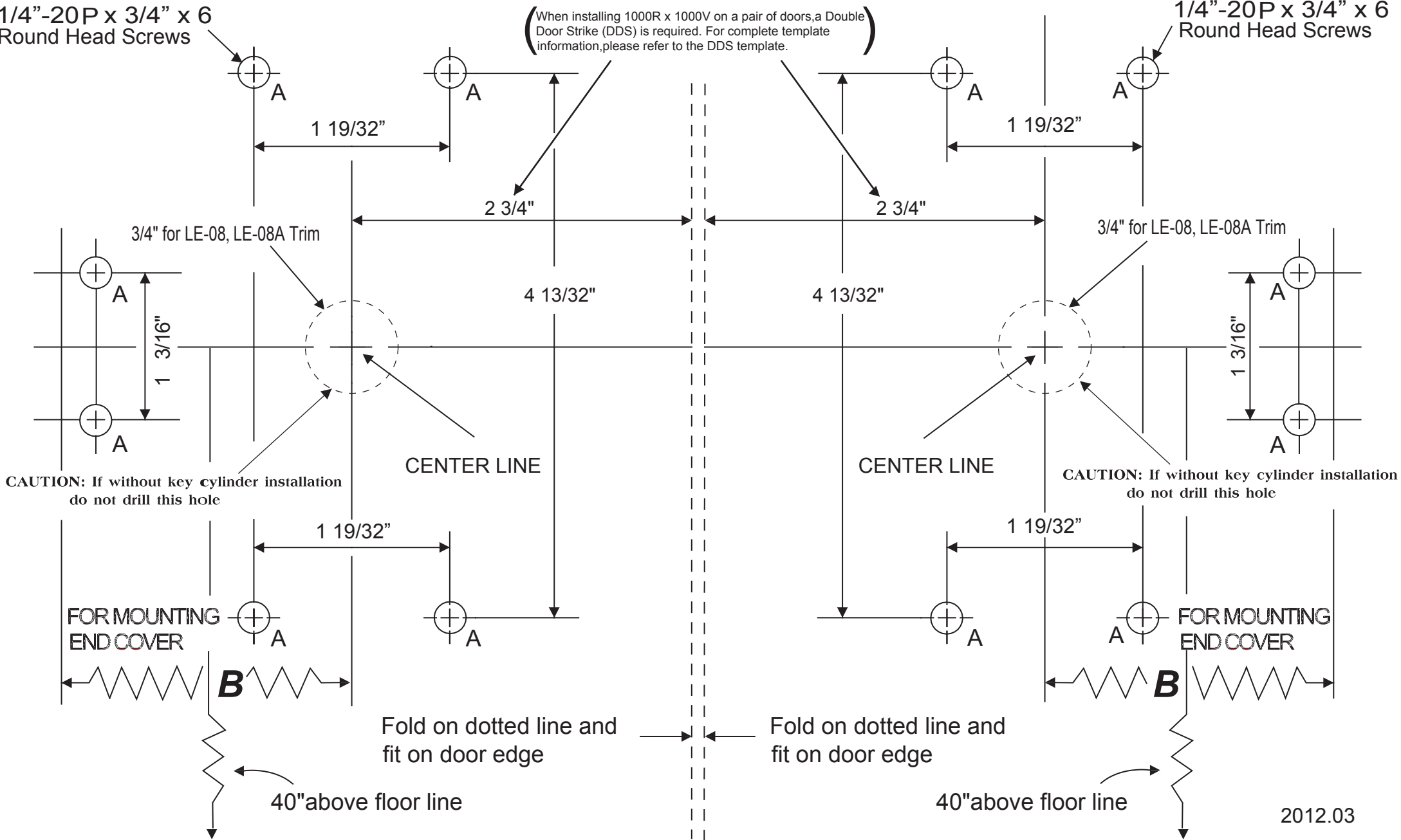

CAUTION: If without key cylinder installation
do not drill this hole

CAUTION: If without key cylinder installation
do not drill this hole

Fold on dotted line and
fit on door edge

Fold on dotted line and
fit on door edge

40" above floor line

40" above floor line

2012.03

TEMPLATE(B-2)

- (A) For 1000V series (UL Listed)-drill & tap for (2) 1/4"-20Px3/4" machine screws (C,D) for bottom latch assembly
Or, drill (2) 3/16" pilot holes(C,D) for self tapping machine screws or wood screws for bottom latch assembly.
- (B) For F1000V (Fire Rated)-drill 9/32" holes (C,D) inside and 3/8" holes(C,D) outside for the (2) thru bolts.

Note: When installing bottom latch assembly:

1. Drill (1) C hole and install screw but do not tighten all the way.
2. Drill (1) D hole and install and tighten screw.
3. Tighten screw in hole C all the way.

BOTTOM LATCH ASSEMBLY

CAUTION :

Be sure the distance from bottom edge of door to bottom edge of bottom latch base must be 13/32"

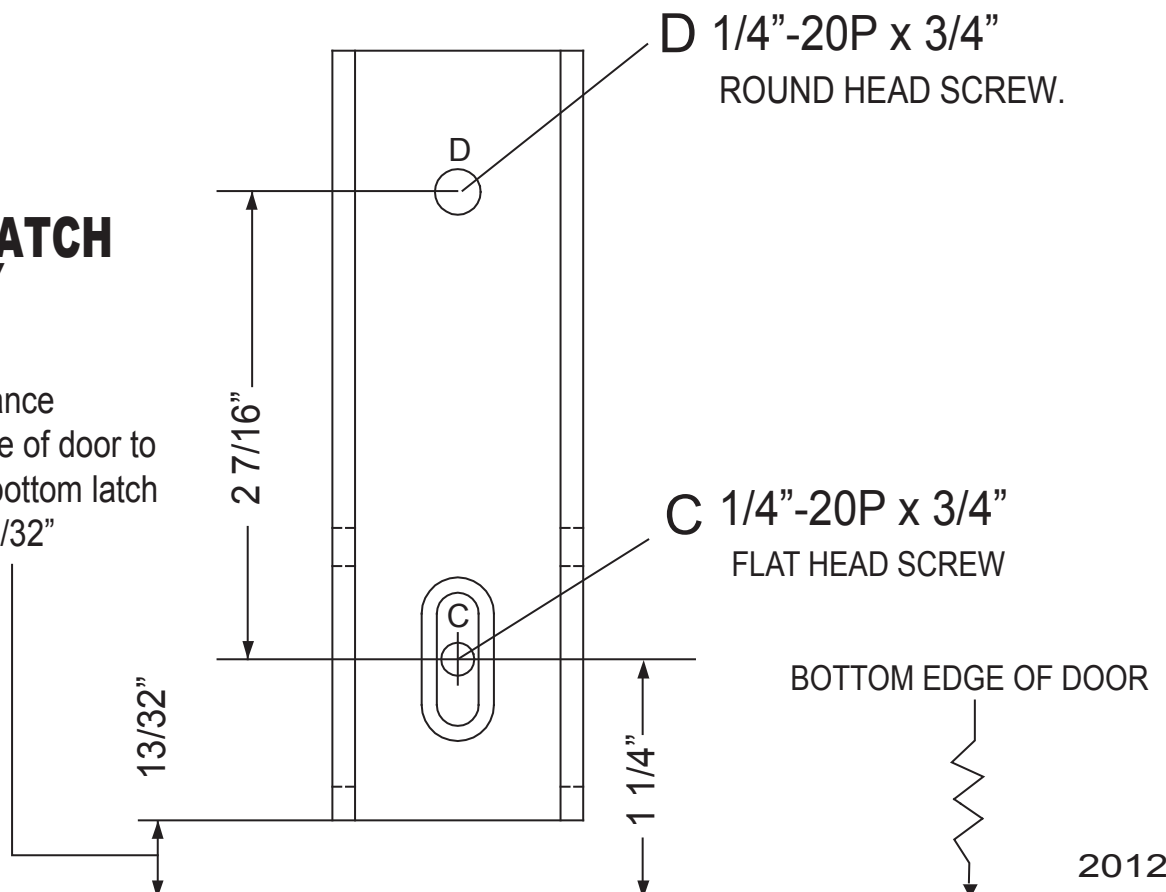

TEMPLATE(B-1)

(A) For 1000V series (UL Listed)-drill & tap for (2) 1/4"-20P x 3/4" machine screws (C,D) for top latch assembly Or, drill (2) 3/16" pilot holes(C,D) for self-tapping machine screws or wood screws for top latch assembly.

(B) For F1000V (Fire Rated)-drill 9/32" holes (C,D) inside and 3/8" holes(C,D) outside for the (2) thru bolts.

F 1/4"-20P x 3/4"
FLAT HEAD MACHINE SCREW

CAUTION :

Drill "F" hole after top latch assembly properly works.

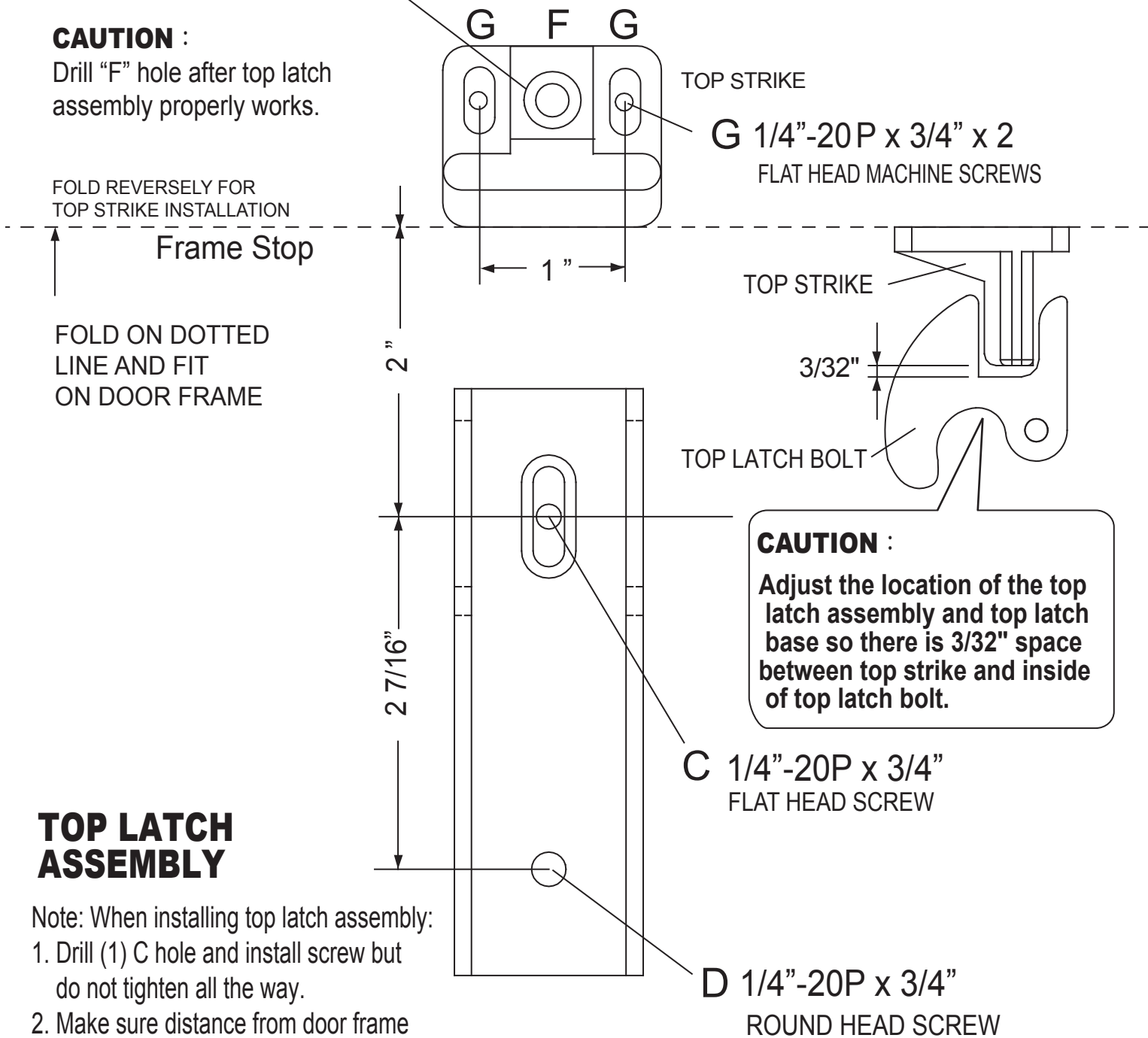

CAUTION :
Adjust the location of the top latch assembly and top latch base so there is 3/32" space between top strike and inside of top latch bolt.

TOP LATCH ASSEMBLY

Note: When installing top latch assembly:

1. Drill (1) C hole and install screw but do not tighten all the way.
2. Make sure distance from door frame to line W is 2".
3. Drill (1) D holes and install and tighten screws.
4. Tighten screw in hole C all the way.