

# TEMPLATE FOR INSTALLING PANIC EXIT DEVICE

2012.03

*outside face of the door*

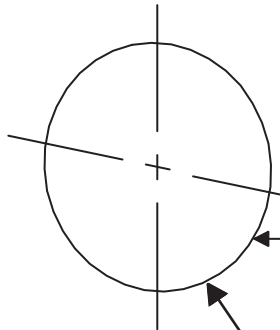

(A) 1 1/4" for Rim Cylinder  
For 2P-03NL, DFP-03NL, FP-03NL  
(B) 3/4" For LE-08, LE-08A  
(C) 2 1/8" for KIL Trims.

HOLE MUST BE DRILLED ACCORDING TO TRIM TEMPLATE.

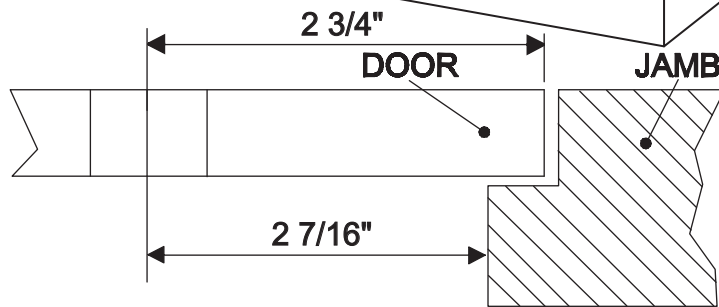

**NOTE:**

Backset of 2 7/16" from jamb to center or 2 3/4" from door edge to center is acceptable. Strike shim can be used or not used to make adjustments to the roller strikes projection to compensate for doors with different backsets.

(A) For 1000R Series (UL Listed)-Drill & tap for (6) 1/4"x20 machine screws for Exit Device and Drill & tap for (3) 1/4"x20 machine screws for Roller Strike  
OPTIONAL for 1000R (UL Listed)

Drill (6) 3/16" Pilot Holes for Self Tapping machine screws or wood screws for Exit Device and

Drill (3) 3/16" Pilot Holes for Self Tapping machine screws or wood screws for Roller Strike

(B) For F1000R (Fire Rated)-Drill 9/32" holes inside and 3/8" holes outside for the (6) thru bolts and drill & tap for (3) 1/4"x20 machine screws for Roller Strike.

