

(A) For 1000V Series (UL Listed)-Drill & tap for (6) 1/4"-20P x 3/4" machine screws for exit device.

Drill (6) 3/16" pilot holes for self-tapping machine screws or wood screws for exit device.

**TEMPLATE (A)**

(B) For F1000V (Fire Rated)-Drill 9/32" holes inside and 3/8" holes outside for the (6) thru bolts.

**FOR RIGHT HAND DOOR INSTALLATION**

**FOR LEFT HAND DOOR INSTALLATION**

1/4"-20P x 3/4" x 6  
Round Head Screws

1/4"-20P x 3/4" x 6  
Round Head Screws

(When installing 1000R x 1000V on a pair of doors, a Double  
Door Strike (DDS) is required. For complete template  
information, please refer to the DDS template.)

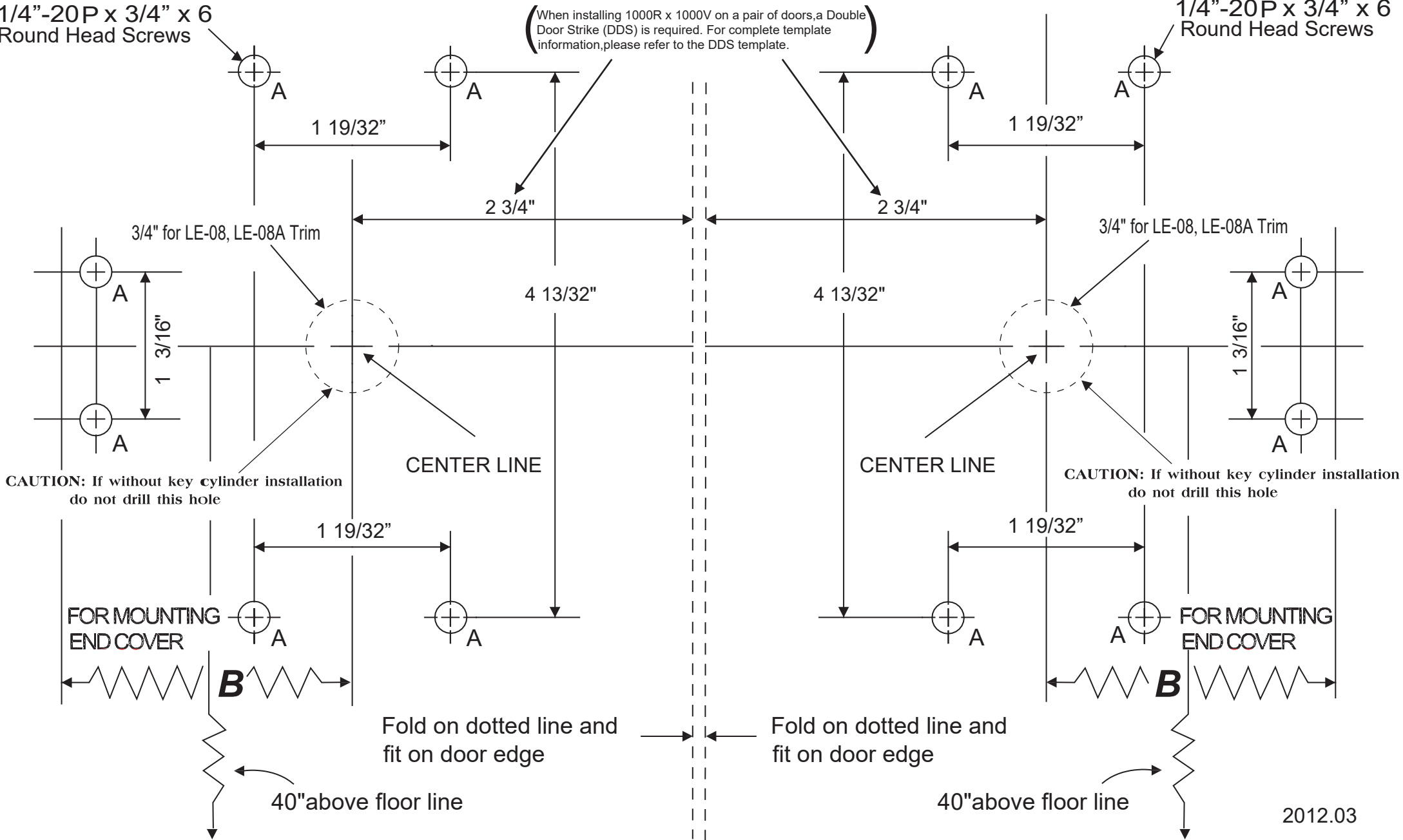

## TEMPLATE(B-2)

- (A) For 1000V series (UL Listed)-drill & tap for (2) 1/4"-20Px3/4" machine screws (C,D) for bottom latch assembly  
Or, drill (2) 3/16" pilot holes(C,D) for self tapping machine screws or wood screws for bottom latch assembly.
- (B) For F1000V (Fire Rated)-drill 9/32" holes (C,D) inside and 3/8" holes(C,D) outside for the (2) thru bolts.

Note: When installing bottom latch assembly:

1. Drill (1) C hole and install screw but do not tighten all the way.
2. Drill (1) D hole and install and tighten screw.
3. Tighten screw in hole C all the way.

### BOTTOM LATCH ASSEMBLY

#### CAUTION :

Be sure the distance from bottom edge of door to bottom edge of bottom latch base must be 13/32"

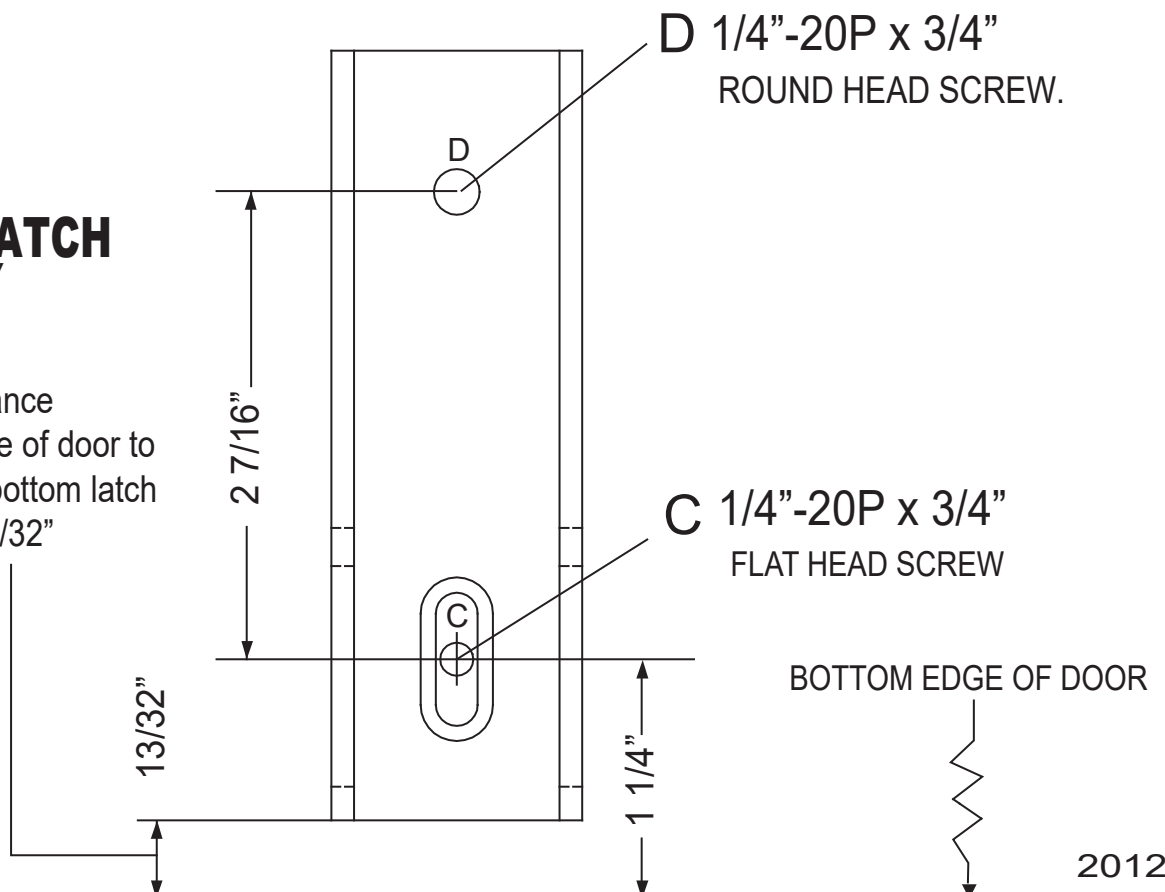

# TEMPLATE(B-1)

(A) For 1000V series (UL Listed)-drill & tap for (2) 1/4"-20P x 3/4" machine screws (C,D) for top latch assembly Or, drill (2) 3/16" pilot holes(C,D) for self-tapping machine screws or wood screws for top latch assembly.

(B) For F1000V (Fire Rated)-drill 9/32" holes (C,D) inside and 3/8" holes(C,D) outside for the (2) thru bolts.

**F 1/4"-20P x 3/4"**  
FLAT HEAD MACHINE SCREW

**CAUTION :**

Drill "F" hole after top latch assembly properly works.

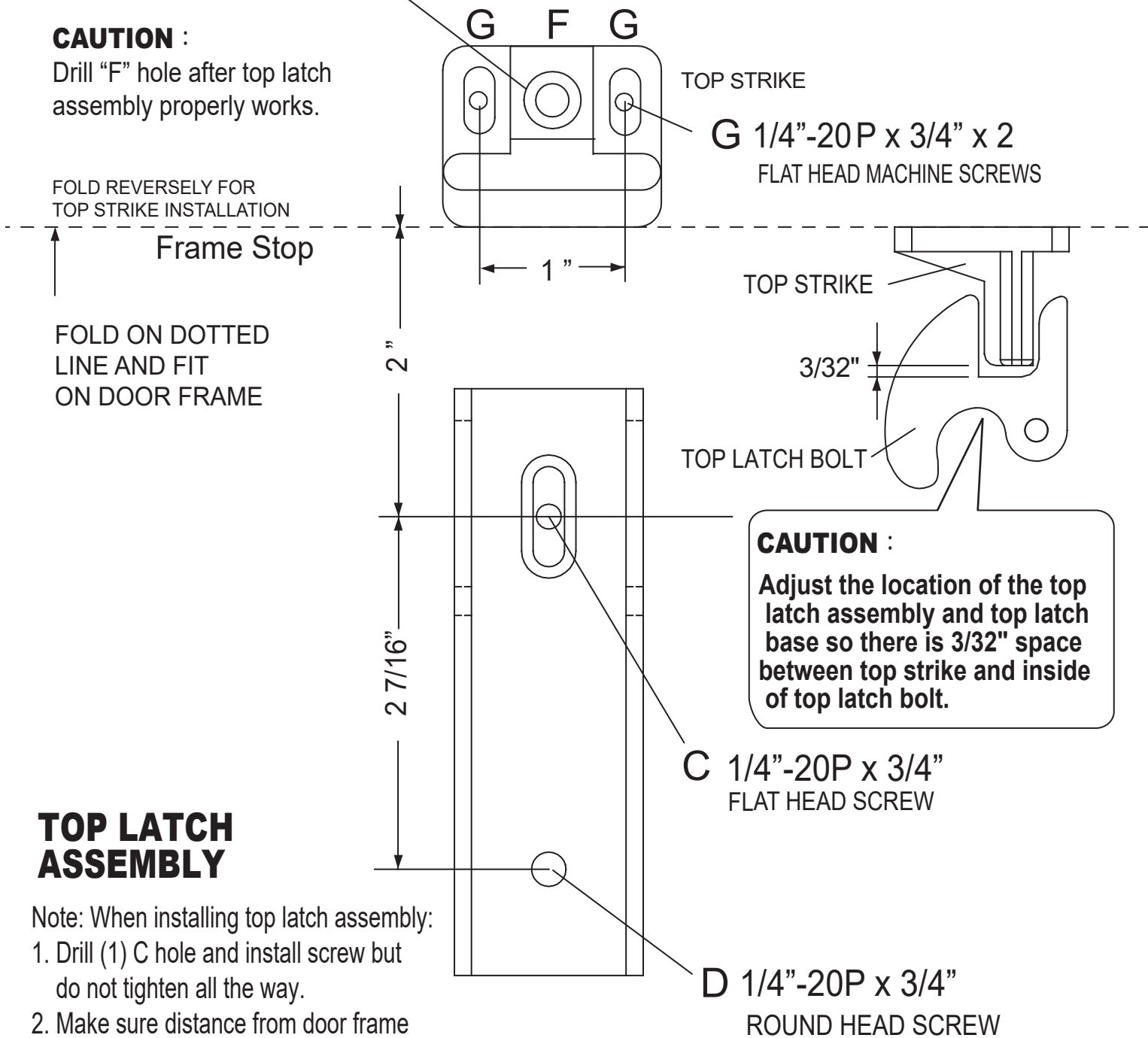

**CAUTION :**  
Adjust the location of the top latch assembly and top latch base so there is 3/32" space between top strike and inside of top latch bolt.

## TOP LATCH ASSEMBLY

Note: When installing top latch assembly:

1. Drill (1) C hole and install screw but do not tighten all the way.
2. Make sure distance from door frame to line W is 2".
3. Drill (1) D holes and install and tighten screws.
4. Tighten screw in hole C all the way.