

316 Adjustable Hold Open Arm

Specifications

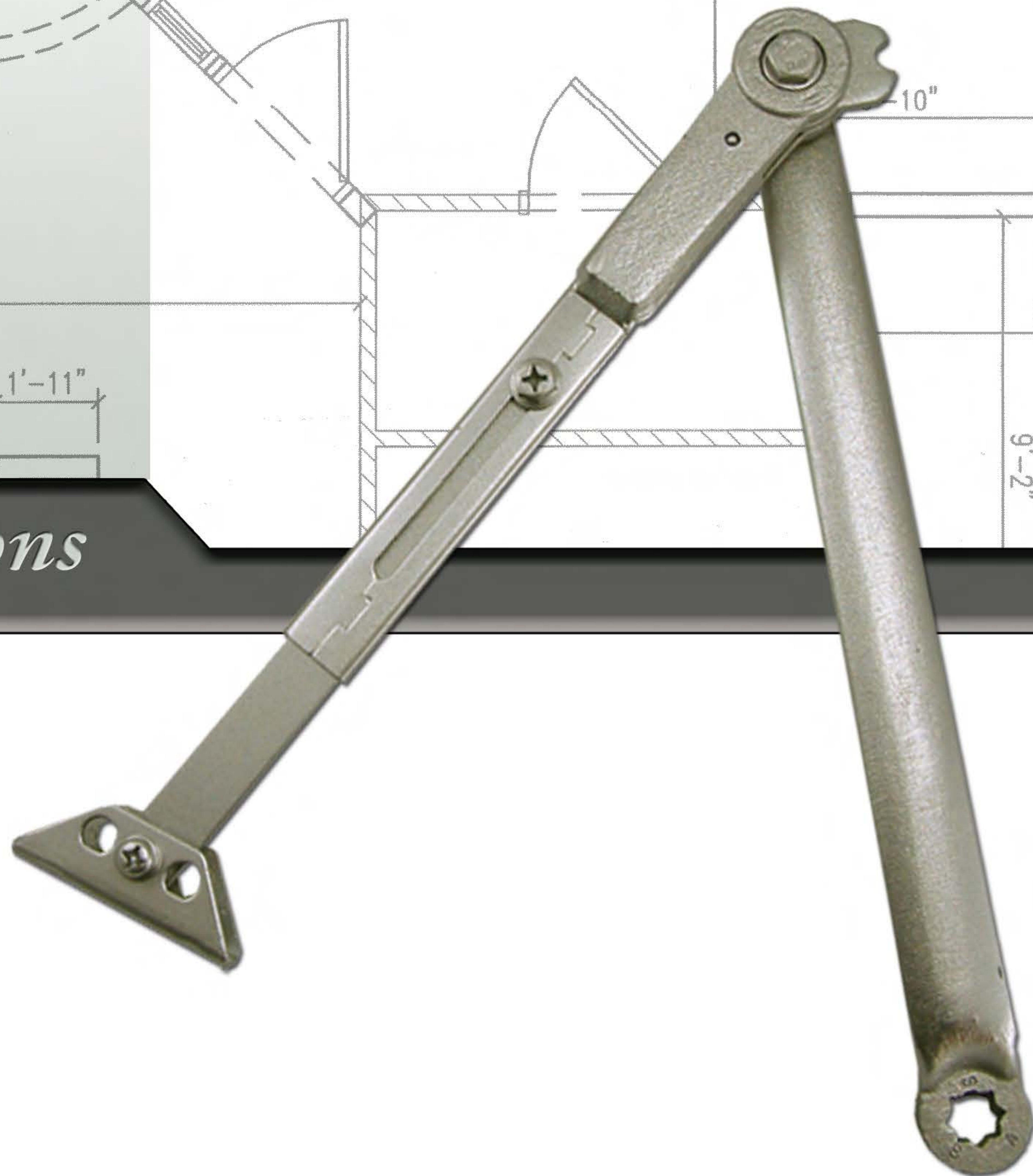

- Base Material :** Forged & Stamped Steel
- Application :** Used to hold doors open in non UL applications
- Controls :** Hold Open Function at elbow using spring loaded ball bearing which allows for an adjustable hold open position
- Handing :** Non Handed
- Mounting :** Regular, Top Jamb & Parallel Arm
- Adjustability :** Slide Arm adjustment for different jamb depths
- Finishes :** AL, BZ, GLD painted finishes
- Fasteners :** Machine, Wood and Self Tapping machine screws
- Warranty :** Limited Lifetime Warranty