

# TEMPLATE FOR INSTALLING PANIC EXIT DEVICE

2012.03

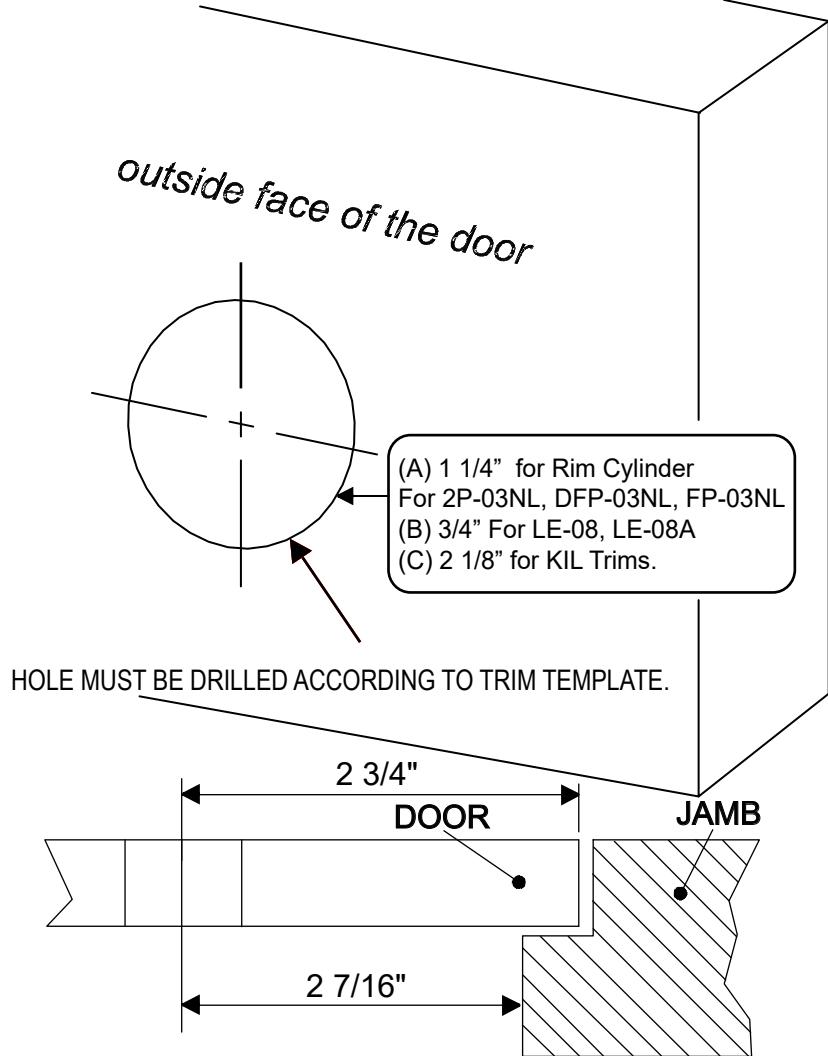

**NOTE:**

Backset of 2 7/16" from jamb to center or 2 3/4" from door edge to center is acceptable. Strike shim can be used or not used to make adjustments to the roller strikes projection to compensate for doors with different backsets.

**ROLLER STRIKE**

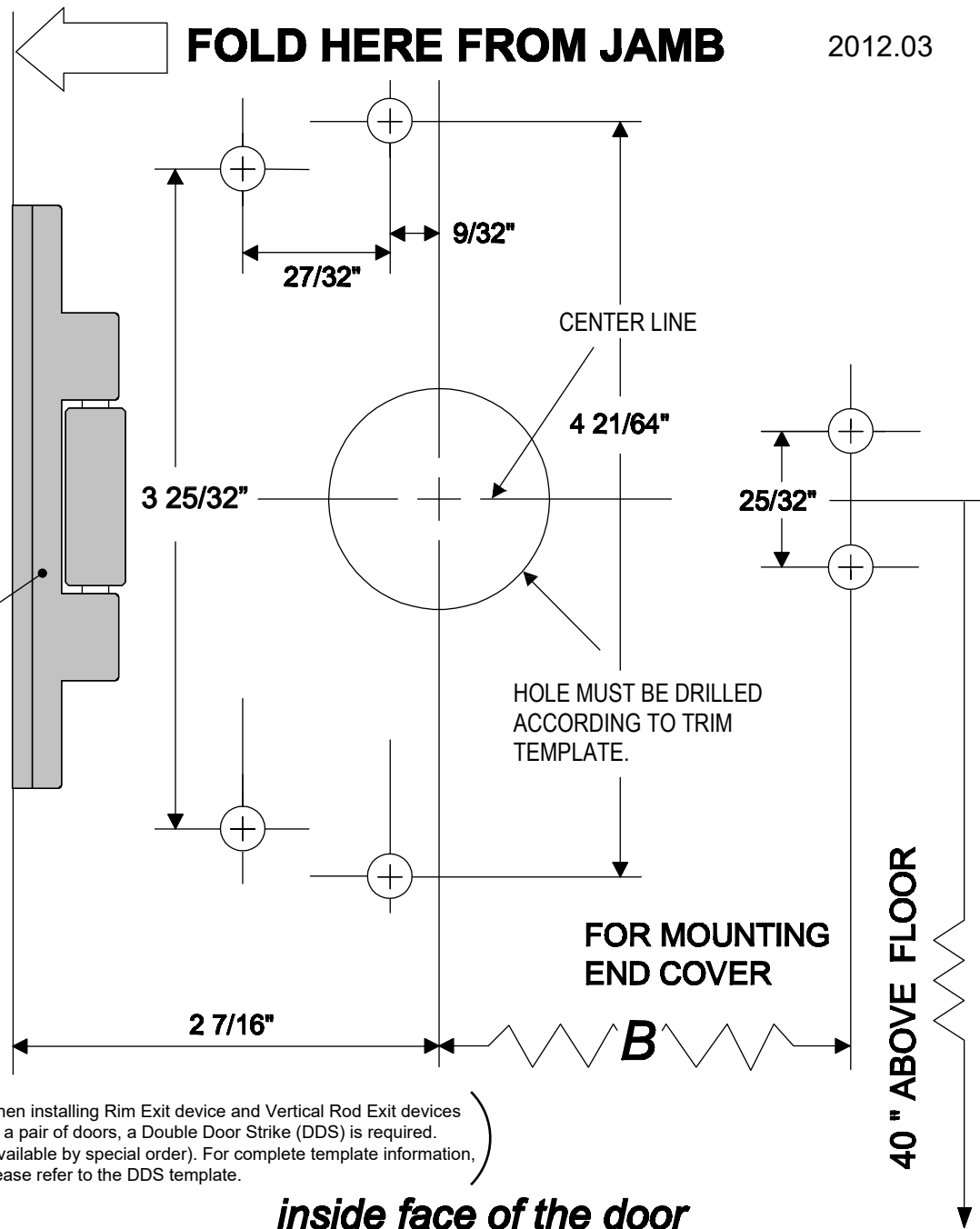

(When installing Rim Exit device and Vertical Rod Exit devices on a pair of doors, a Double Door Strike (DDS) is required. (Available by special order). For complete template information, please refer to the DDS template.)

- (A) For 2000R Series (UL Listed)-Drill & tap for (6) 1/4"x20 machine screws for Exit Device and Drill & tap for (3) 1/4"x20 machine screws for Roller Strike  
OPTIONAL for 2000R (UL Listed)  
Drill (6) 3/16" Pilot Holes for Self Tapping machine screws or wood screws for Exit Device and  
Drill (3) 3/16" Pilot Holes for Self Tapping machine screws or wood screws for Roller Strike
- (B) For F2000R (Fire Rated)-Drill 9/32" holes inside and 3/8" holes outside for the (6) thru bolts and drill & tap for (3) 1/4"x20 machine screws for Roller Strike.