

116 Adjustable Hold Open Arm Installation Instructions

■ CHART TO DETERMINE HAND OF DOOR

■ FINAL ADJUSTMENT AND REGULATING PROCEDURES

PULL SIDE

HINGE SIDE OF DOOR HINGE SIDE OF DOOR

STOP SIDE OF DOOR STOP SIDE OF DOOR

PUSH SIDE

THIS IS A LEFT HAND DOOR THIS IS A RIGHT HAND DOOR

REGULATING DOOR SPEED AND LATCHING SPEED

TURN SPEED REGULATING VALVE CLOCKWISE TO SLOW DOWN COUNTER-CLOCKWISE TO SPEED UP DOOR MOVEMENT

THIS VALVE CONTROLS DOOR SWEEP SPEED THIS VALVE CONTROLS LATCHING SPEED

ADJUSTING FOOT FOR CLOSING POWER

MOVE FOOT PIVOT TO HOLE AS ILLUSTRATED BELOW

LESS POWER MORE POWER

STANDARD POSITION

HINGE EDGE OF DOOR

ADJUST DEGREE OF OPENING THE DOOR

ADJUST THE HEX SCREW FOR HOLD OPEN ARM TO GET THE NEEDED HOLD OPEN DEGREE.

AFTER ADJUSTING THE HEX SCREW MUST BE TIGHTED.

■ STANDARD INSTALLATION: PULL SIDE RIGHT INSTALLATION

- RIGHT HAND DOOR ILLUSTRATED SAME DIMENSIONS APPLY TO LEFT HAND DOOR
- MEASURED FROM HINGE ϕ DIMENSIONS ARE IN $\frac{\text{inches}}{\text{mm}}$
- DO NOT SCALE DRAWING

MODEL	DIMENSIONS "A"		OPENING
	inches	mm	
116 (HOLDARM)	7"	178	T100°
	6"	152	101° TO 120°
	3-1/2"	89	* 121° TO 180°

* Door/Wall/Hardware/Jamb conditions permitting

INSTALLATION INSTRUCTIONS

1. SELECT DEGREE OF DOOR. USE DIMENSIONS SHOWN IN CHART AND ILLUSTRATION ABOVE TO MARK LOCATION OF ATTACHING SCREWS. ON DOOR AND FRAME PREPARE HOLES.
2. ASSEMBLE MAIN ARM TO CLOSER.
3. ATTACH CLOSER TO DOOR WITH SPEED REGULATING VALVES TOWARD HINGE.
4. ATTACH THE FOOT OF THE FOREARM TO FRAME.
5. ADJUST LENGTH OF FOREARM TO POSITION FOREARM AT RIGHT ANGLE TO FRAME TIGHTEN THE SCREW OF FOREARM.
6. SNAP PINION CAP OVER SPINDLE AT BOTTOM OF CLOSER
7. ADJUST DOOR CLOSER
8. LOOSEN THE INNER HEX SCREW AT THE ELBOW OF THE MAIN ARM, OPEN THE DOOR TO THE ANGLE YOU NEED, THEN TIGHTEN THE INNER HEX SCREW TO HOLD THE DOOR OPEN.

POSITION OF ARMS AND INDEX SETTINGS

RIGHT HAND DOOR LEFT HAND DOOR

RIGHT ANGLE RIGHT ANGLE

LOCKNUT FOREARM FOREARM

ELBOW WASHER AND SCREW

CLOSING SPEED CONTROL

CAUTION DO NOT BACK VALVES OUT OF CLOSER OR A LEAK WILL RESULT

CLOSED

10°

STANDARD CLOSING CYCLE

CLOSING

ATTENTION: ADJUST CLOSING SPEED TIME TO BETWEEN 4 TO 6 SECONDS FROM 90°. USE OF THE DOOR BY HANDICAPPED, ELDERLY OR SMALL CHILDREN MAY REQUIRE LONGER CLOSING TIME.

Not to scale 1:1. Measurements are for reference only. Not a drilling template.

OTHER INSTALLATION: PUSH SIDE TOP JAMB INSTALLATION

- LEFT HAND DOOR ILLUSTRATED SAME DIMENSIONS APPLY TO RIGHT HAND DOOR
- DIMENSIONS ARE IN $\frac{\text{inches}}{\text{(mm)}}$, MEASURED FROM HINGE \perp
- DO NOT SCALE DRAWING

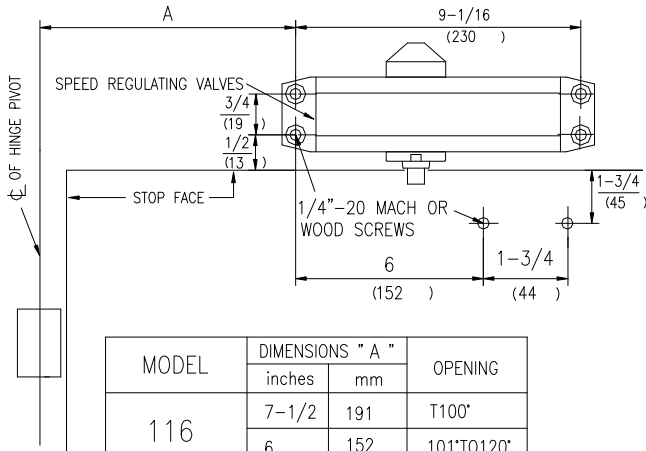

MODEL	DIMENSIONS "A"		OPENING
	inches	mm	
116 (HOLDARM)	7-1/2	191	T100"
	6	152	101" TO 120"
	3-1/2	89	*121" TO 180"

* Door/Wall/Hardware/Jamb conditions permitting

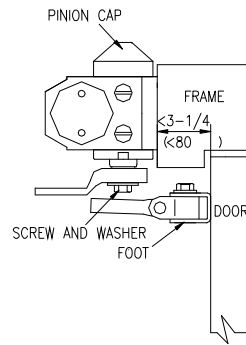

INSTALLATION INSTRUCTIONS

1. SELECT DEGREE OF DOOR. USE DIMENSIONS SHOWN IN CHART AND ILLUSTRATION ABOVE TO MARK LOCATION OF ATTACHING SCREWS ON DOOR AND FRAME PREPARE HOLES
2. ASSEMBLE MAIN ARM TO CLOSER.
3. ATTACH CLOSER TO FRAME WITH SPEED REGULATING VALVES TOWARD HINGE.
4. ATTACH THE FOOT OF THE FOREARM TO DOOR.
5. ADJUST LENGTH OF FOREARM TO POSITION FOREARM AT RIGHT ANGLE TO FRAME WHEN CONNECTED TO MAIN ARM AT ELBOW USE WASHER AND SCREW PROVIDED TO SECURE PIVOT CONNECTION. TIGHTEN LOCKNUT ON FOREARM
6. SNAP PINION CAP OVER SPINDLE AT BOTTOM OF CLOSER

OTHER INSTALLATION: PUSH SIDE PARALLEL INSTALLATION

- RIGHT HAND DOOR ILLUSTRATED SAME DIMENSIONS APPLY TO LEFT HAND DOOR
- MEASURED FROM HINGE \perp DIMENSIONS ARE IN $\frac{\text{inches}}{\text{(mm)}}$
- DO NOT SCALE DRAWING

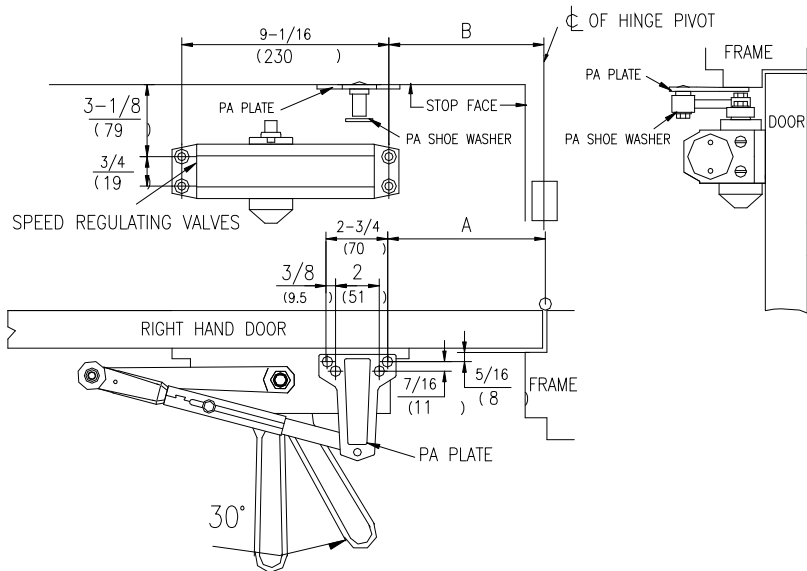

MODEL	DIMENSIONS "A"		DIMENSIONS "B"		OPENING
	inches	mm	inches	mm	
116	9-1/4	235	7-5/8	194	TO 120"
	7-3/4	197	6-1/8	156	*121" TO 180"

* Door/Wall/Hardware/Jamb conditions permitting

INSTALLATION INSTRUCTIONS

1. SELECT DEGREE OF DOOR. USE DIMENSIONS SHOWN IN CHART AND ILLUSTRATION ABOVE TO MARK LOCATION OF ATTACHING SCREWS ON DOOR AND FRAME PREPARE HOLES
2. ATTACH CLOSER TO DOOR WITH SPEED REGULATING VALVES BACK TO HINGE.
3. ATTACH MAIN ARM AS FOLLOW:
 - (A) PLACE OPEN END WRENCH ON BOTTOM SHAFT & TURN TOWARD HINGE ABOUT 30°.
 - (B) PLACE MAIN ARM ON TOP SHAFT, INSERT ARM SCREW INTO TOP OF SHAFT AND TIGHTEN.
4. ATTACH PA PLATE TO TOP FRAME AS SHOWN.
5. REMOVE FOOT FROM FOREARM AND DISCARD.
6. FASTEN FOREARM TO PA PLATE USING SCREW REMOVED FROM FOOT IN STEP 4 AND PA SHOE WASHER INCLUDED IN SCREW PACK.
7. ADJUST LENGTH OF FOREARM TO POSITION MAIN ARM AT PARALLEL TO FRAME WHEN CONNECTED TO MAIN ARM AT ELBOW USE WASHER AND SCREW PROVIDED TO SECURE PIVOT CONNECTION. TIGHTEN LOCKNUT
8. SNAP PINION CAP OVER SPINDLE AT BOTTOM.

APPLICABLE DOOR: WEIGHT 20-85 Kg

Not to scale 1:1. Measurements are for reference only. Not a drilling template.