

Cylinder Dogging Kit for 1000 Series Installation Instructions

Step 1

Remove end cap ,old slide cover,
and dogging device.

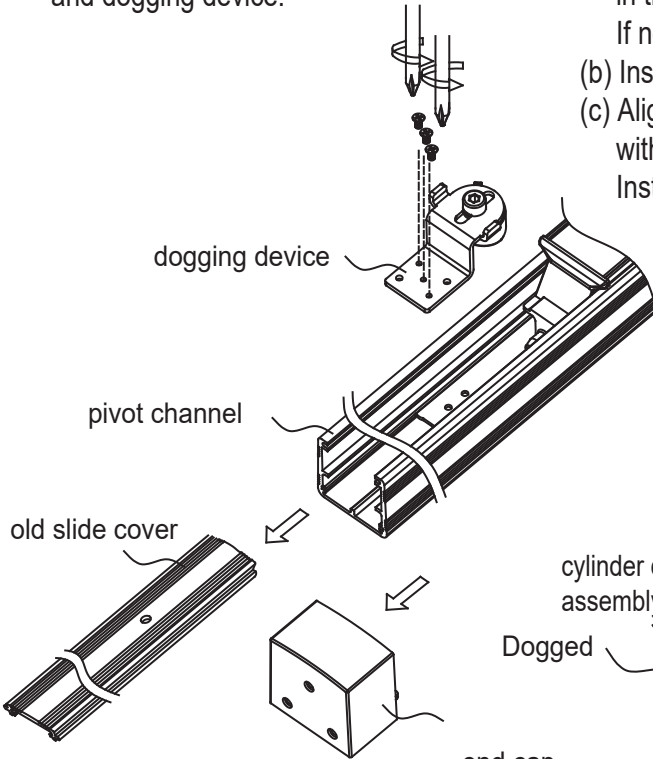

Step 2

(a) Make sure cam of cylinder dogging assembly is
in the "U" (Un-Dogged) position.

If not , move the cam to the "U" position.

(b) Insert cylinder dogging assembly into pivot channel.

(c) Align the 3 screw holes on the cylinder dogging assembly
with the 3 matching screw holes on the inside plate.
Install the 3 screws and tighten until tight.

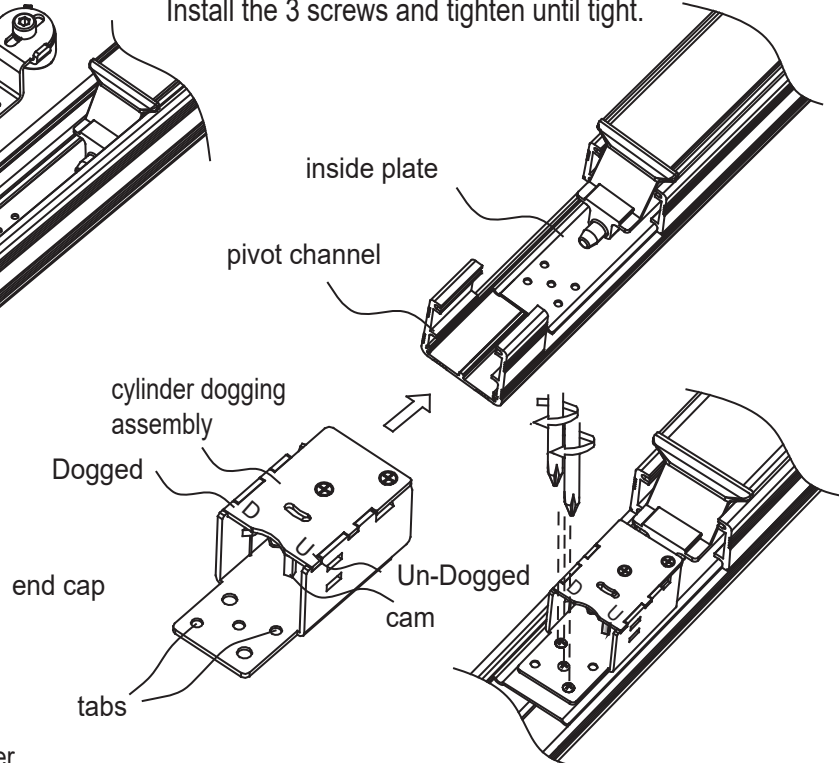

Step 3

(a) Insert back plate into new slide cover.

(b) Install cylinder collar onto the mortise cylinder and insert into new slide cover and back plate.
Then, thread cylinder retaining ring onto cylinder until finger tight.

(c) Insert new assembled slide cover into the pivot channel .Install end cap.

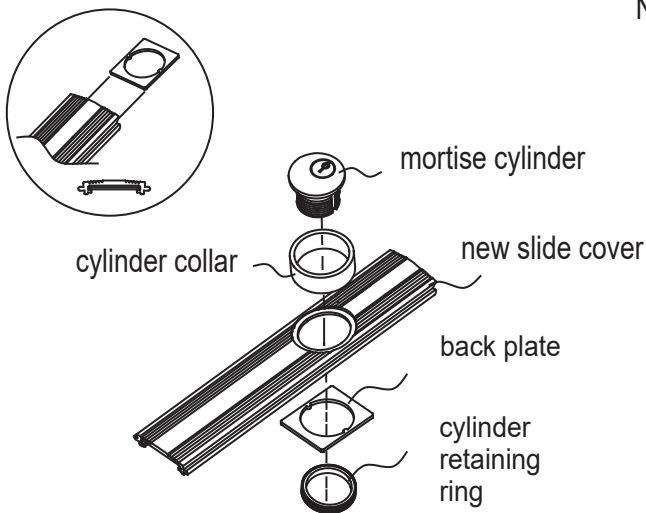

Note : plug direction downwards
to head cover.

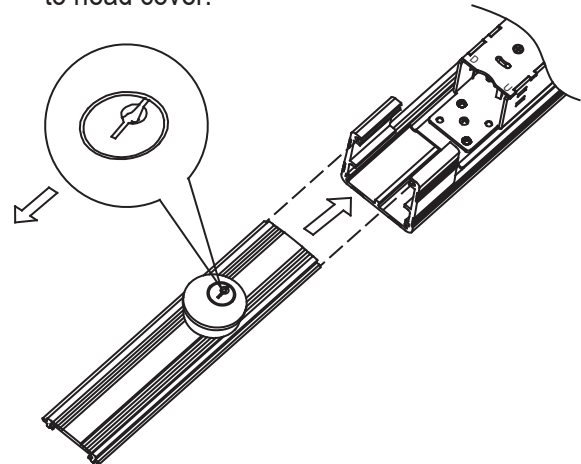

Step 4 Test Operation

(a) Dogging Exit Device :

Depress touchbar to retract latchbolt .
Insert and turn key 180° counter-clockwise
to dog down touchbar and hold latchbolt
in retracted position.
Turn key 180° clockwise to remove key.

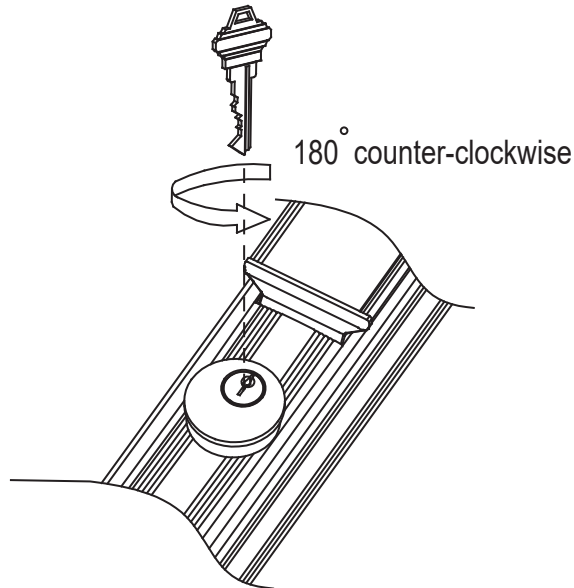

(b) Un – Dogging Exit Device :

Insert and turn key 180° clockwise until a click
sound is heard.
Touchbar will spring up and latchbolt will spring out.
Turn key 180° counter-clockwise and remove key.

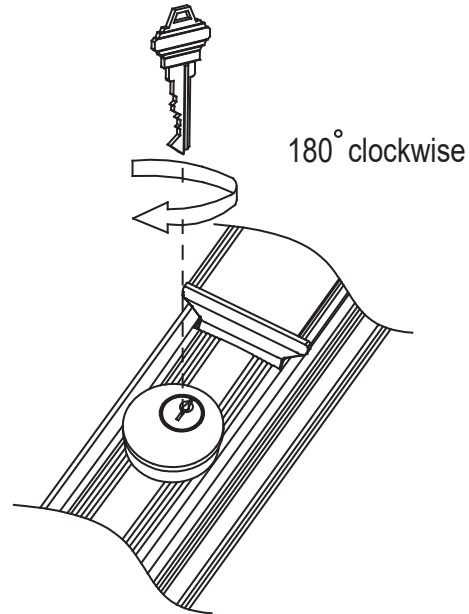

(c) Install end cap.

